

6-ACHSIGER INTERMODALWAGEN
MIT INTEGRIERTEN KÖRBN
6-AXLE INTERMODAL WAGON
WITH INTEGRATED BASKETS

Sdggmrss DTW M28

Der erste 6-achsige Intermodalwagen mit zwei integrierten Körben ist für den Transport und den Umschlag von nicht kranbaren und kranbaren Sattelauflegern bis zu einem Maximalgewicht von 40 t ausgelegt. Dazu sind keine spezielle Hebevorrichtungen notwendig, zusätzliche Kosten aufgrund logistischem Mehraufwand fallen weg. Der Wagen verfügt über das grösste Lademass des Kompatibilitätskodes „e“ nach IRS 50 596-5.

The first 6-axle intermodal wagon with two integrated baskets is designed for the transport and handling of non-cranable and cranable semi-trailers up to a maximum weight of 40 t. No special lifting equipment is required and additional costs due to extra logistical effort are eliminated. The wagon has the largest loading gauge of compatibility code „e“ according to IRS 50 596-5.

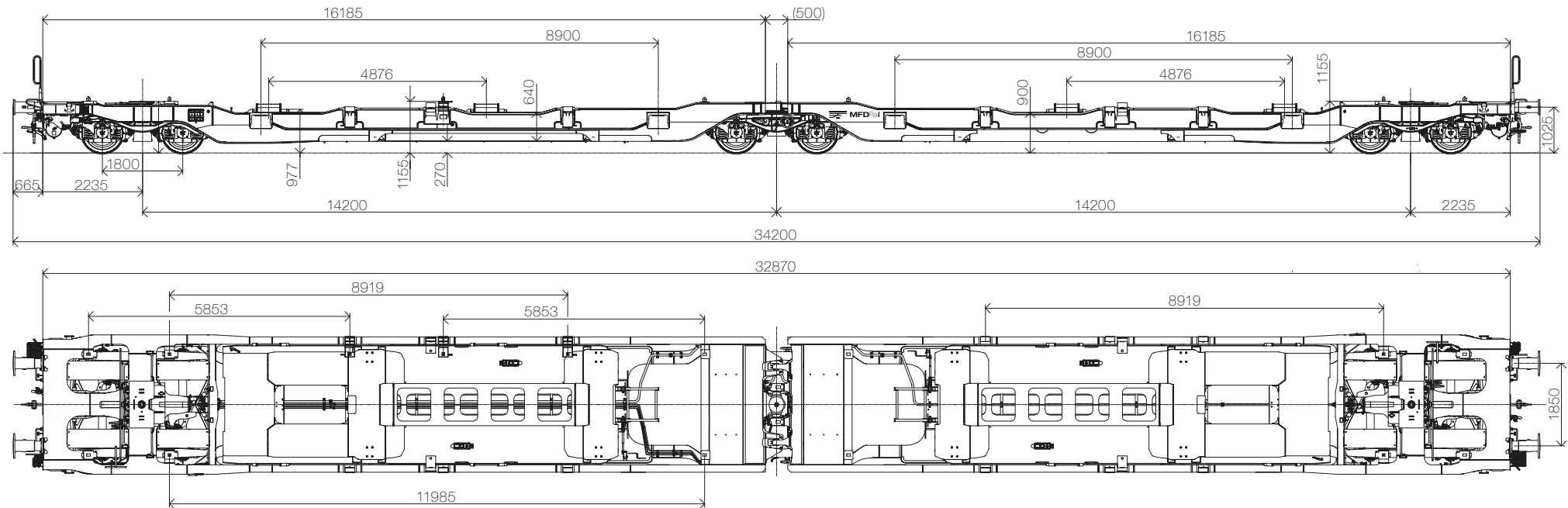

6-ACHSIGER INTERMODALWAGEN
MIT INTEGRIERTEN KÖRBEN
6-AXLE INTERMODAL WAGON
WITH INTEGRATED BASKETS

Sdggmrss DTW M28

TECHNISCHE DATEN /Technical Data:

Eigengewicht: /Tare Weight:	43.0 t	Bremssohlen (K): /Brake blocks:	Jurid 816M 320
Max. Zuladung: /Max. Load:	92.0 t	Bremse: /Brake:	2 x KE-GP-A
Radsatzlast: /Axle Load:	22.5 t	Puffer: /Buffers:	Kat. L 150 / 2750
Schraubenkupplung: /Screw coupling:	1'350 kN	Handbremsgewicht: /Handbrake weight:	20.0 t / 25.6 kN
Zugvorrichtung: /Pulling device:	1'500 kN	Fährschiff: /Ferry boats:	1°30'
Drehgestell: /Bogie:	2 x Y25 Ls(s)i1e + 1 x Y25 Ls(s)i1fe	Klimazone: /Climate zone:	T1

BETRIEBSDATEN /Operating Data:

Länge über Puffer: /Total length over buffers:	34.20 m	Bremseinstellung: /Brake adjustment:	SS
Ladelänge: /Loading length:	2 x 16.185 m	Geschwindigkeit max.: /Max. speed:	120 km/h
Drehzapfenabstand: /Pivot spacing:	2 x 14.20 m	Containerzapfen: /Containerpins:	2 x 12
Ladehöhe ab S.O.: /Loading height from top of rail:	1'155 mm	Einsatzbereich: /Range of use:	TEN / GE
Kurvenradius: /Curve-radius:	Einzelwagen /Single wagon 75 m Zugsverband /Train set 150m	Lichtraumprofil: /Clearance profile:	G1
Max. Bremsgewicht: /Max. brake weight:	108 t	Körbe: /Baskets: 2 Stk. für die Beladung von nicht kranbaren Trailern 2 pcs. for loading non-cranable trailers	

LASTGRENZRASTER /Load limits:

	A	B	C	D	
S	53.0	65.0	77.0	92.0	★★★
SS	53.0	65.0	77.0		

STÜTZBOCKHÖHEN /Trailer hitch height:

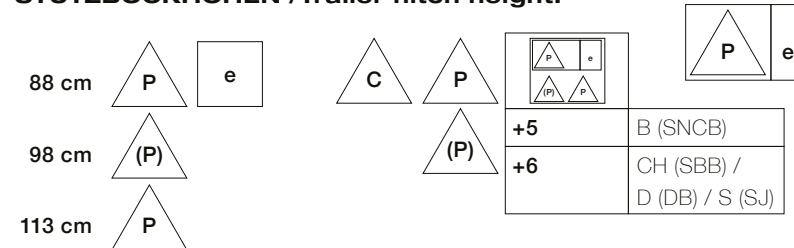

BELADESCHEMA /Loading scheme M28:

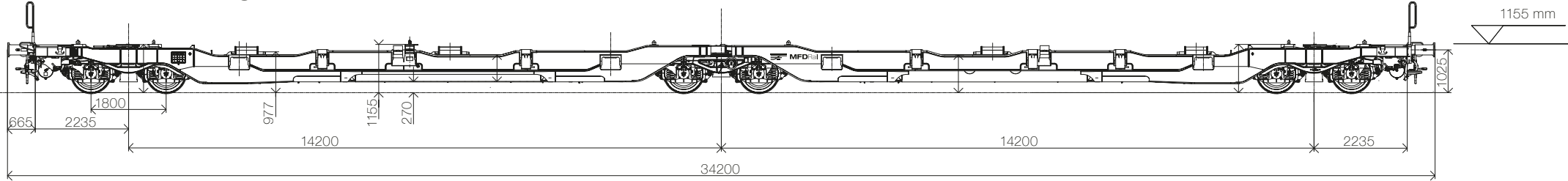

+				+				+				+				+			
+				+				+				+				+			
20 ↓ 24	0	0	0	20 ↓ 24	20	23	19.5	20 ↓ 24	0	0	0	20 ↓ 24	20	23	19.5	20 ↓ 24	0	0	0
	8	10	8		18.5	21	18		8	10	8		18.5	21	18		0	0	0
	12	15	12		17.5	20	17		12	15	12		17.5	20	17		16	20	16
	16	20	16		17	19	16.5		16	20	16		20	25	20		24	30	24
	20	25	20		16	18	15.5		20	25	20		24	30	24		28	32	28
	24	30	24		15.5	17	14.5		24	30	24		28	32	28		32	34	31
	28	32	28		14.5	16.5	14		28	32	28		32	34	31		33	36	32
	32	34	31		7.5	14.5	7		32	34	31		33	36	32		34.5	36	33.5
	33	36	32		4.5	9	4		33	36	32								
	34.5	36	33.5		0	0	0												

+				+				+				+				+									
+				+				+				+				+									
20 ↓ 24	20	23	19.5	20 ↓ 24	0	0	0	91 ↓ 96	0	0	0	91 ↓ 97	40	91 ↓ 97	45	81 ↓ 86	0	0	0	81 ↓ 86	30				
	18.5	21	18		8	10	8		36	36	36		8		10		8	36	36		36	36	36	36	30
	18	20	17		12	15	12		36	36	36		12		15		12	36	36		36	36	36	36	31
	17	19	16.5		16	20	16		36	36	36		16		20		16	36	36		36	36	36	36	20
	16.5	18.5	15.5		20	25	20		36	36	36		20		25		20	36	36		36	36	36	36	26
	15.5	17.5	15		24	30	24		36	36	36		24		30		24	36	36		36	36	36	36	
	15	17	14		28	32	28		36	36	36		28		32		28	36	36		36	36	36	36	
	7.5	14.5	7		32	34	31		36	36	36		32		34		31	36	36		36	36	36	36	
	4.5	9	4		33	36	32		36	36	36		33		36		32	36	36		36	36	36	36	
	0	0	0		34.5	36	33.5		36	36	36		34.5		36		33.5	36	36		36	36	36	36	
									36	36	36							36	36		36	36	36	36	
									36	36	36							36	36		36	36	36	36	

BELADESCHEMA /Loading scheme M28:

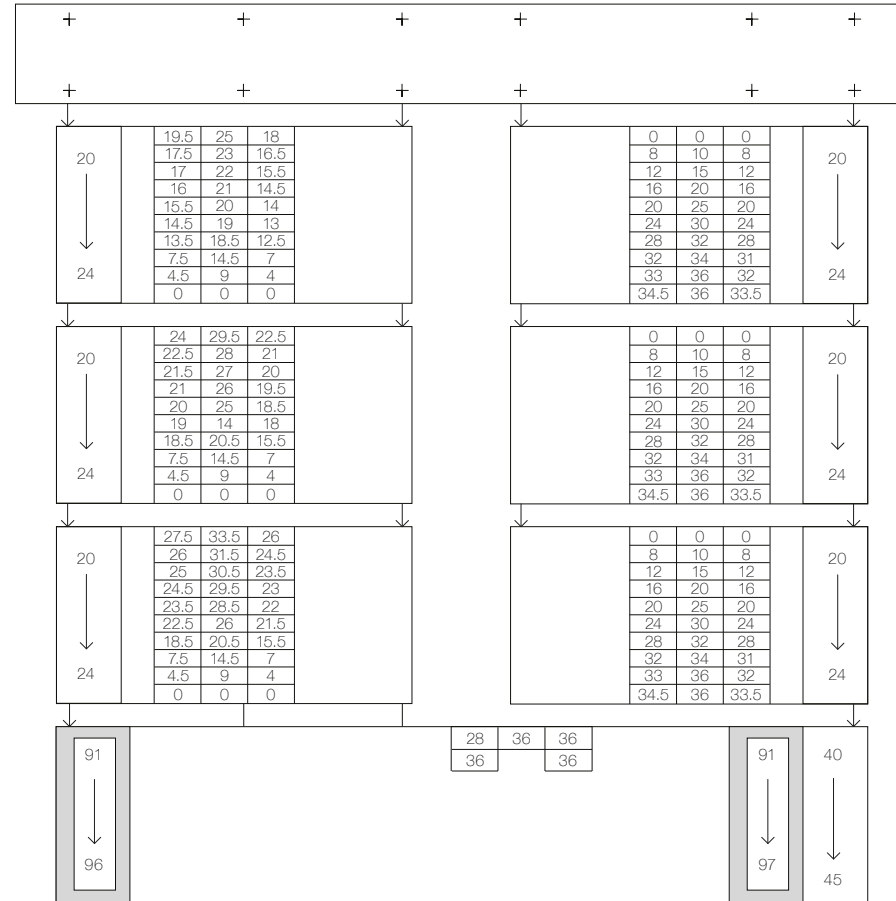
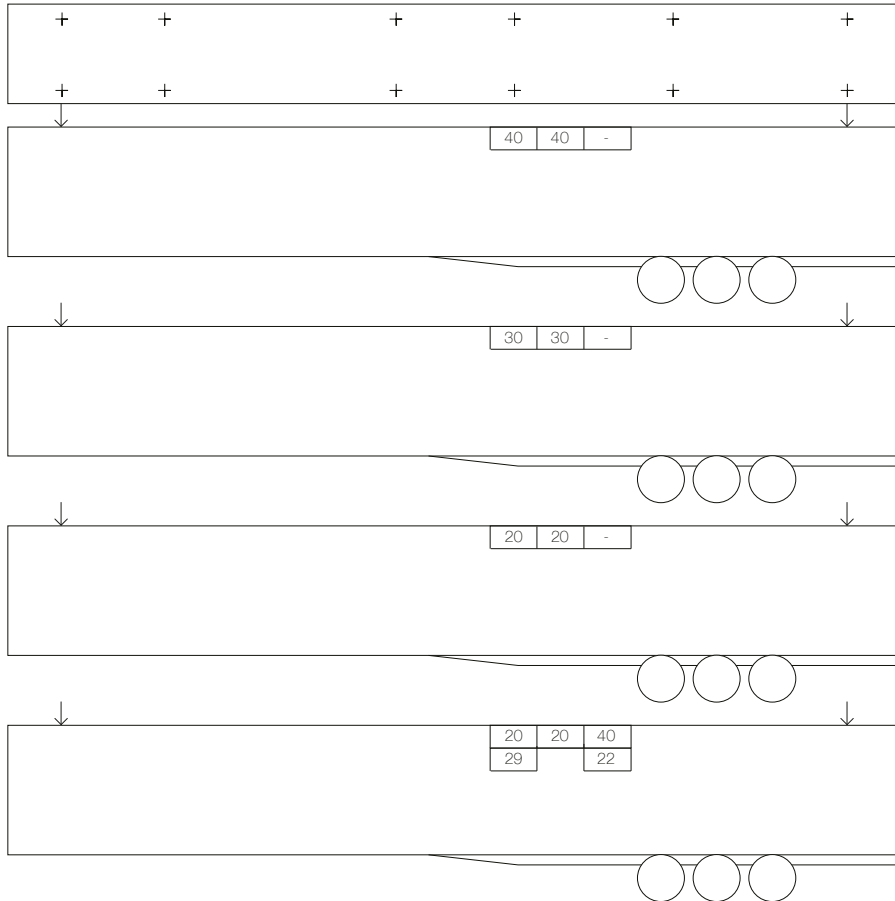
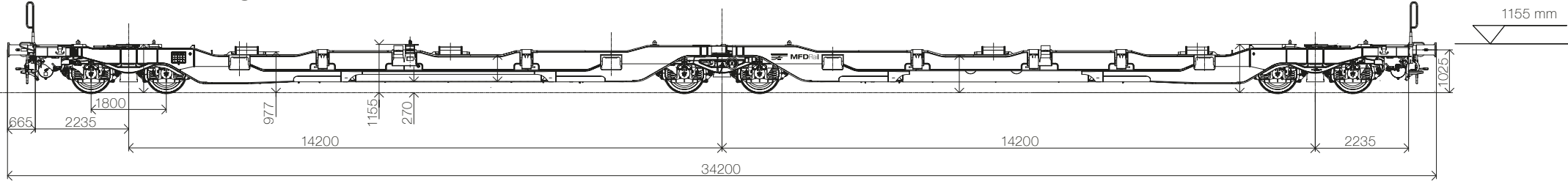

BELADESCHEMA /Loading scheme M28:

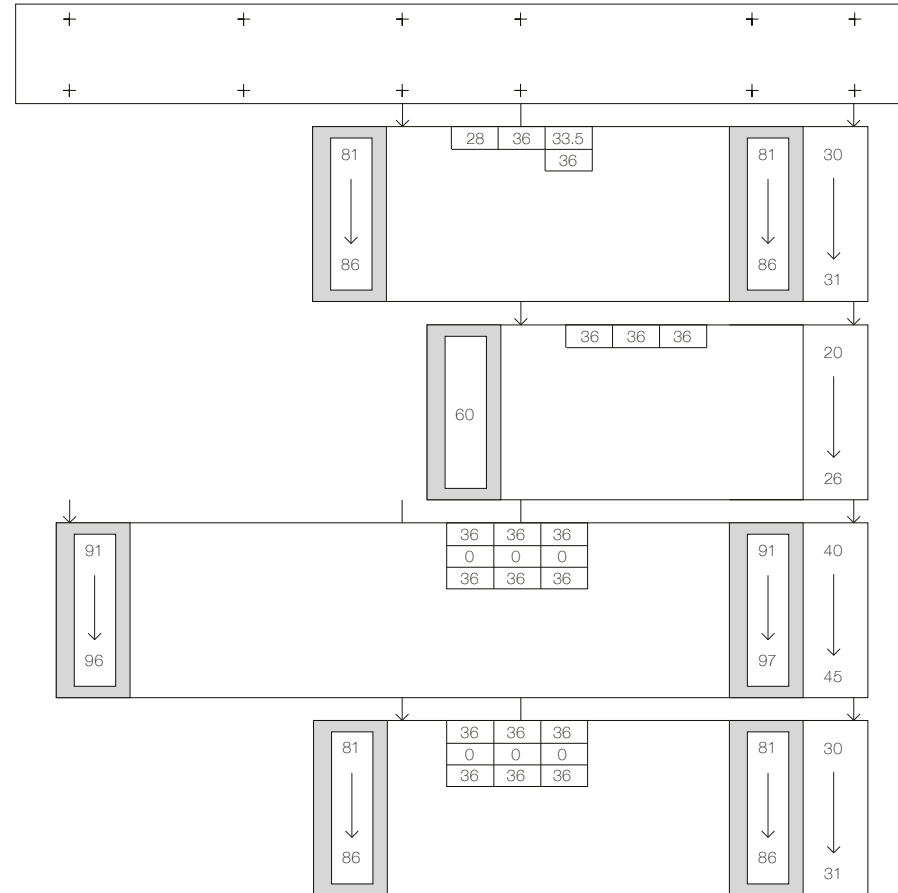
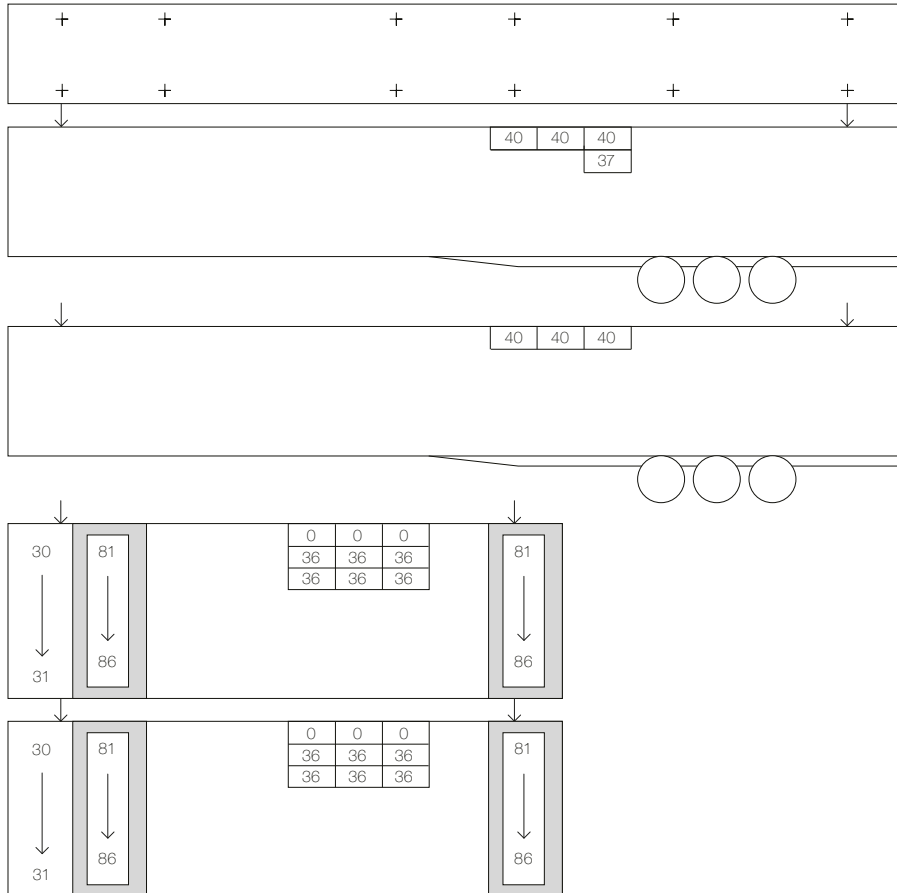
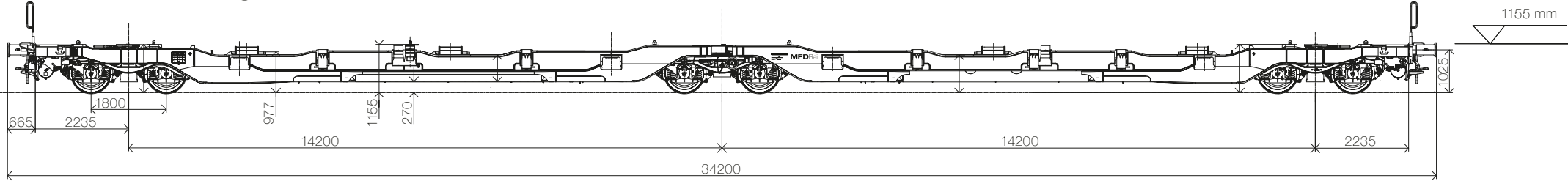

BELADESCHEMA /Loading scheme M28:

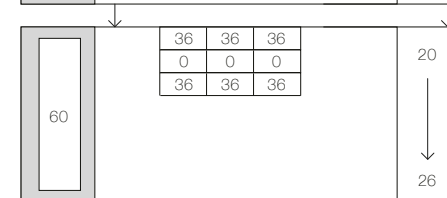
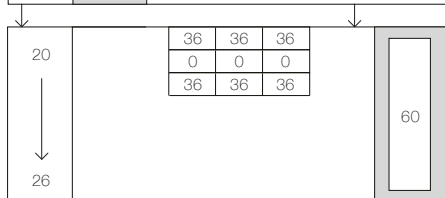
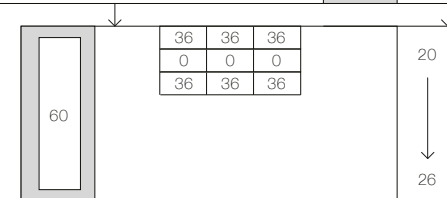
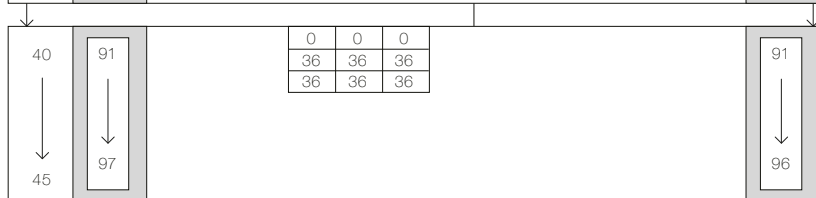
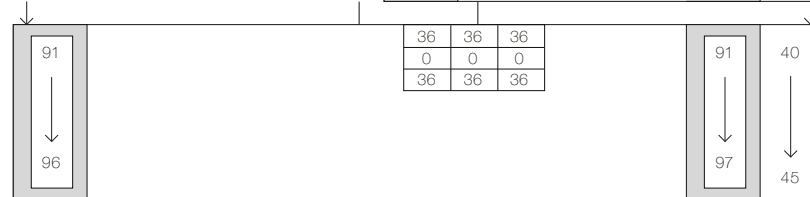
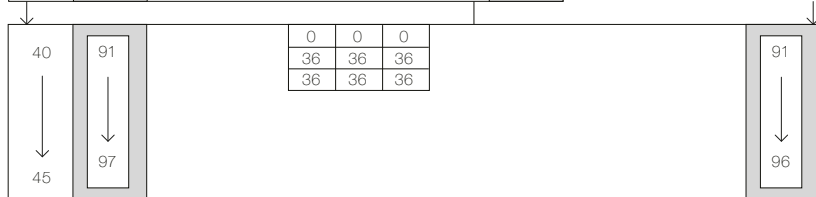
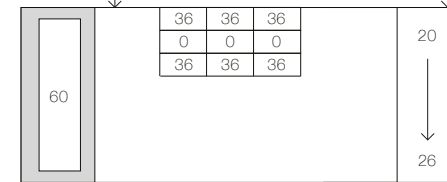
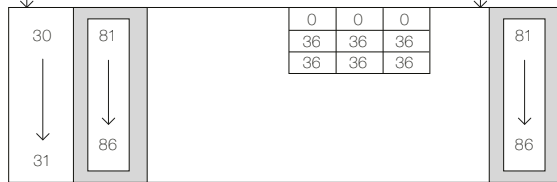
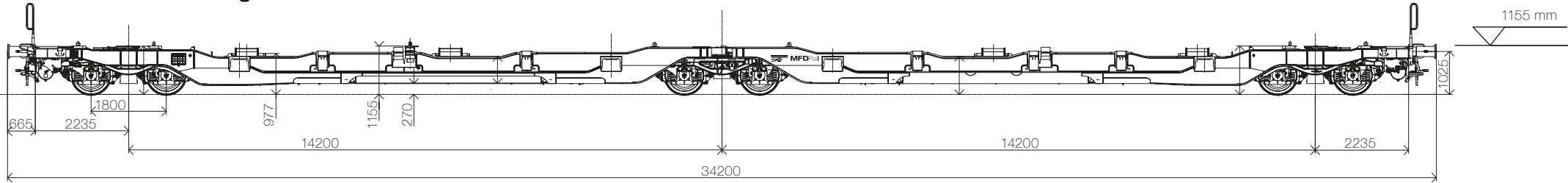

BELADESCHEMA /Loading scheme M28:

