

6-ACHSIGER CONTAINERWAGEN  
 6-AXLE CONTAINER CARRIER

# Sggrss 80<sup>◇</sup> M2

Dieser 6-achsige Gelenkwagen eignet sich mit einer Ladelänge von 80' optimal für den maritimen Verkehr und den Transport von 20', 30' und 40' Containern. Mit seinem hohen Ladegewicht von 108 t in Kombination mit der 80' Ladelänge, garantiert dieser Wagen das ideale Verhältnis zwischen Ladelänge und Gewicht.

*This 6-axle articulated railcar with a loading length of 80' is ideally suited for maritime traffic and the transport of 20', 30' and 40' containers. With its high loading capacity of 108 t in combination with the 80' loading length, this railcar guarantees the ideal ratio between loading length and weight.*

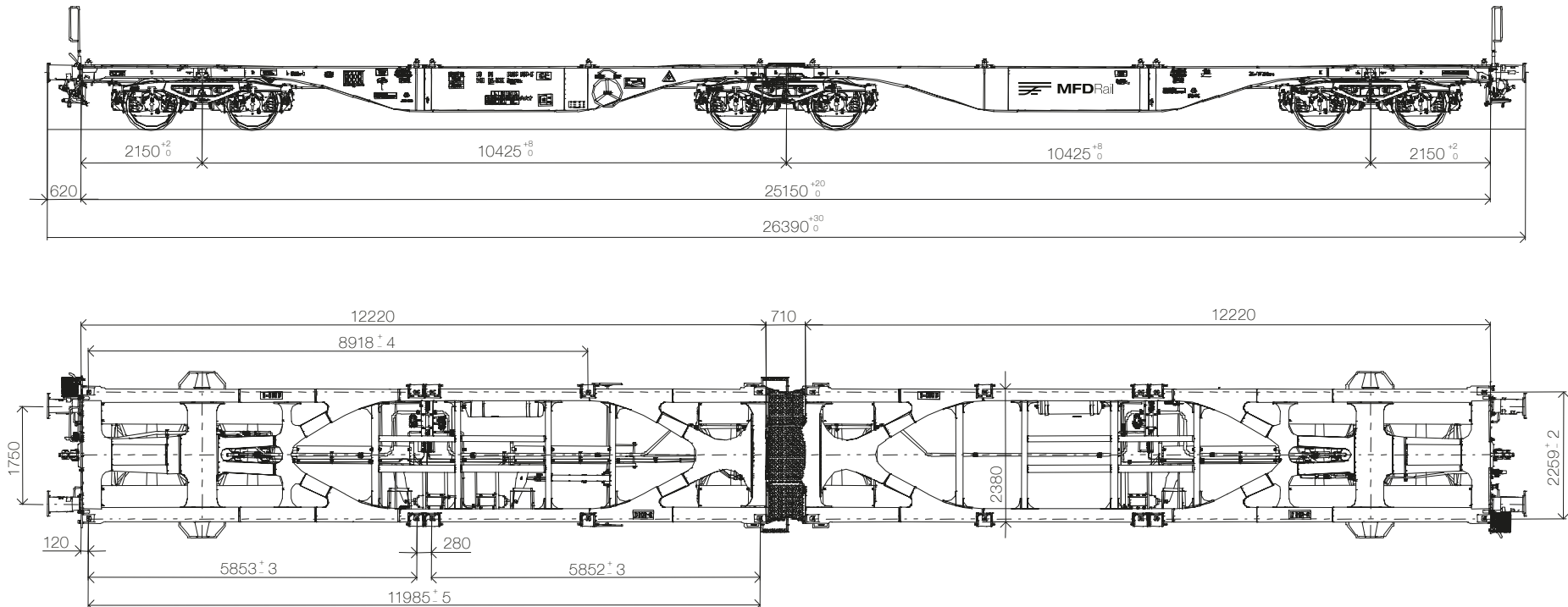

6-ACHSIGER CONTAINERWAGEN  
6-AXLE CONTAINER CARRIER

# Sggrss 80<sup>◇</sup> M2

## TECHNISCHE DATEN /Technical Data:

Eigengewicht: /Tare Weight:	ca. 26.7 t	Drehgestell: /Bogie:	Y25 Ls(s)d1
Max. Zuladung: /Max. Load:	108.2 t	Bremssohlen (K): /Brake blocks:	Jurid 816M 320
Radsatzlast: /Axle Load:	22.5 t	Bremse: /Brake:	2 x KE-GP-A
Radsatzbauart: /Wheelset type:	ULT 25	Puffer: /Buffers:	Kat. A 105 / 2750
Radsatzlager: /Wheelset bearing:	BA 182	Handbremsgewicht: /Handbrake weight:	22.9 t / 23.1 kN
Schraubenkupplung: /Screw coupling:	1'350 kN	Fährschiff: /Ferry boats:	1°30'
Zugvorrichtung: /Pulling device:	1'500 kN		

## BETRIEBSDATEN /Operating Data:

Länge über Puffer: /Total length over buffers:	26.39 m	Bremseinstellung: /Brake adjustment:	SS
Ladelänge: /Loading length:	2 x 12.22 m	Geschwindigkeit max.: /Max. speed:	120 km/h
Drehzapfenabstand: /Pivot spacing:	2 x 10.425 m	Containerzapfen: /Containerpins:	2 x 10
Ladehöhe ab S.O.: /Loading height from top of rail:	1'155 mm	Einsatzbereich: /Range of use:	TEN / GE
Kurvenradius: /Curve-radius:	Einzelwagen 75 m Zugsverband 150m	Lichtraumprofil: /Clearance profile:	G1
Max. Bremsgewicht: /Max. brake weight:	108 t	Klimazone: /Climate zone:	T1

## LASTGRENZRASTER /Load limits:

	A	B	C	D	
S	69.2	81.2	96.2	108.2	★★★
SS	69.2	81.2	93.2		

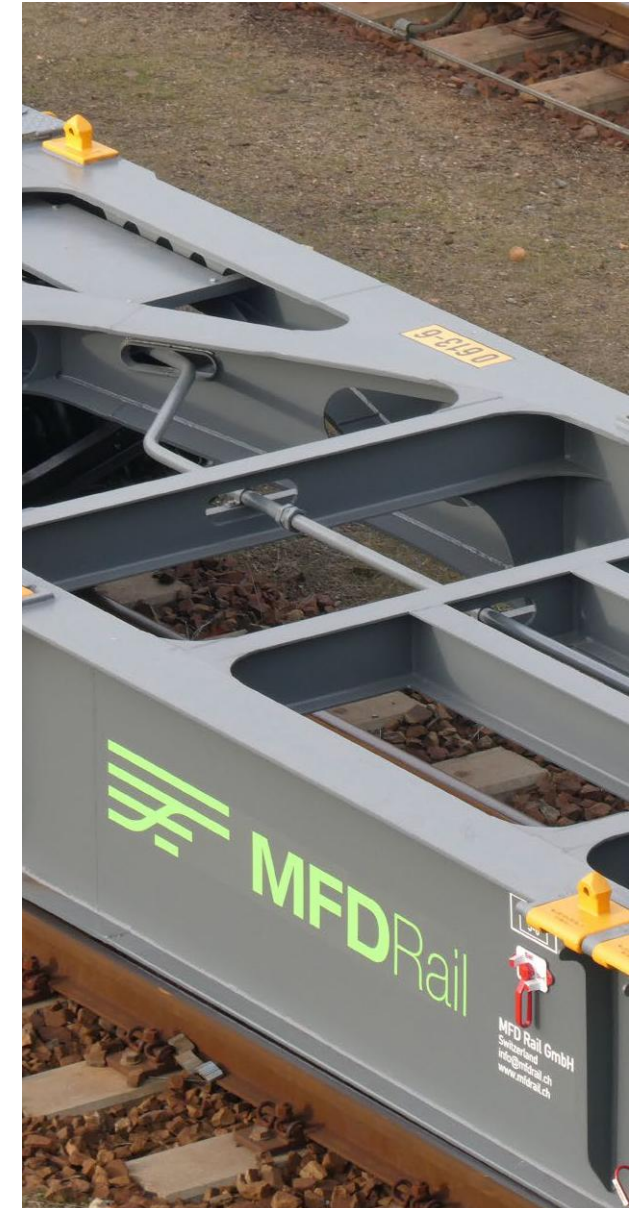

6-ACHSIGER CONTAINERWAGEN  
6-AXLE CONTAINER CARRIER

# Sggrss 80<sup>◇</sup> M2

**BELADESCHEMA**  
**/Loading scheme M2:**

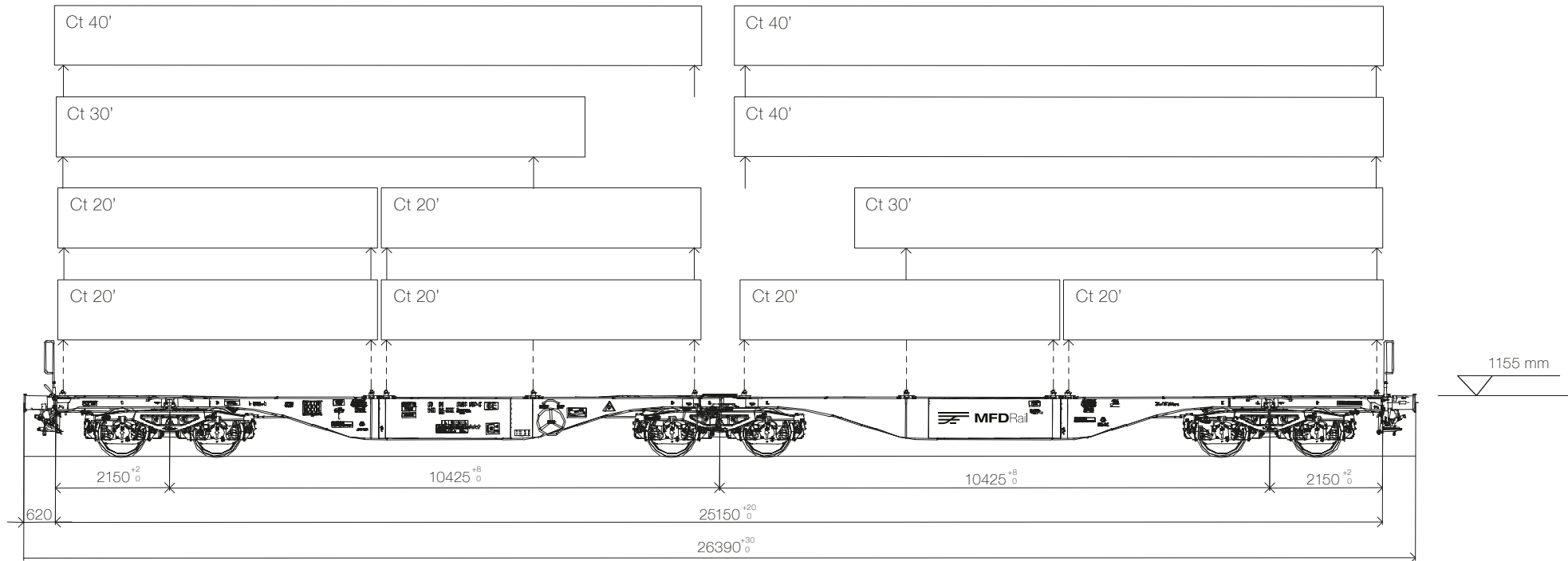

**BELADESCHEMA**  
/Loading scheme M2:

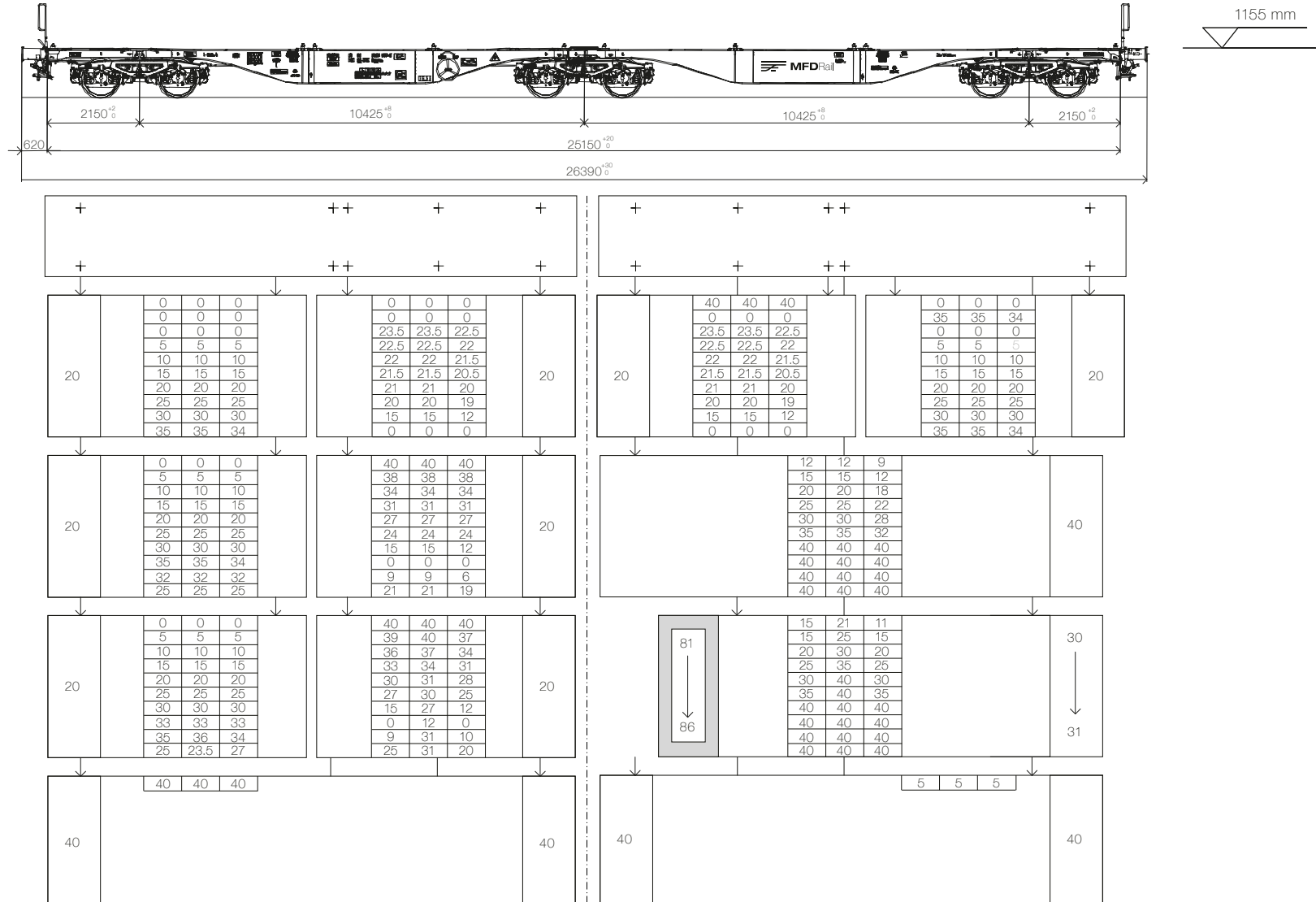

**ERKLÄRUNGEN FÜR BELADESCHEMAS /Explanations for loading scheme:**

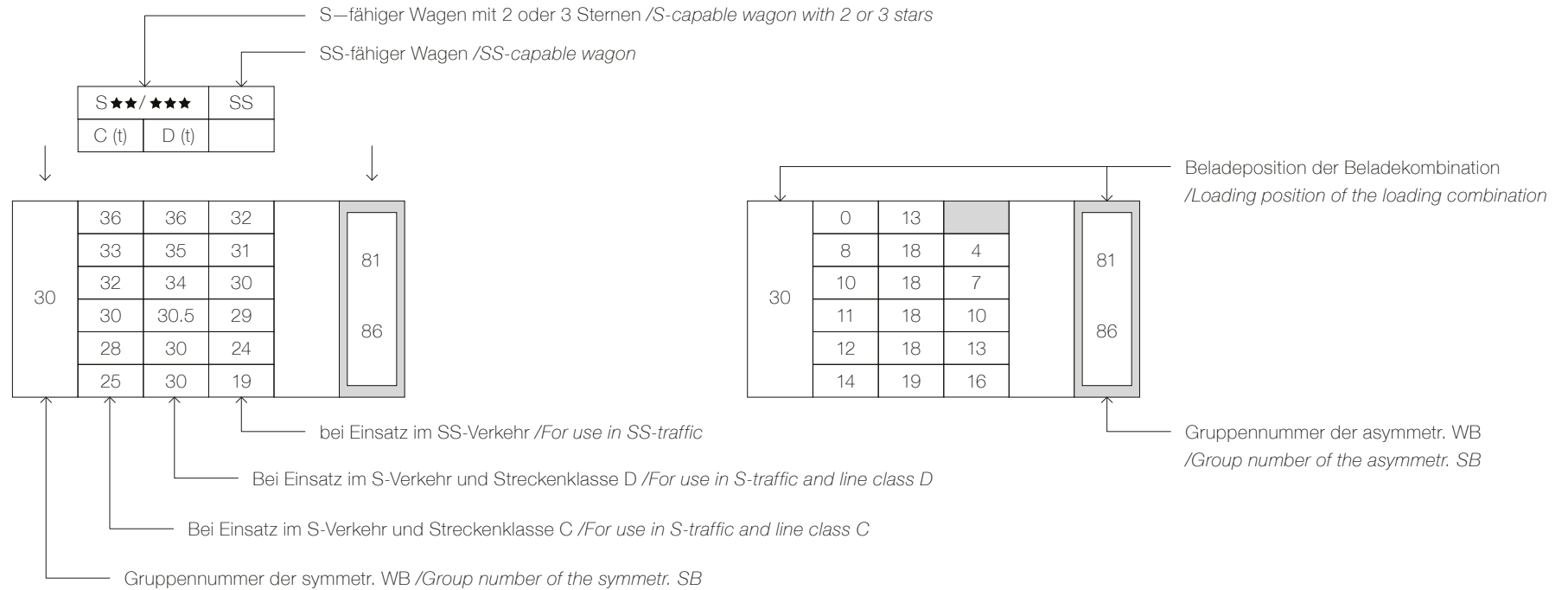

- ★ Fester Containerzapfen /Fixed container pin
- + Seitlich nicht verschiebbarer, klappbarer Containerzapfen /foldable container spigots that cannot be moved sideways
- 0 Leerer Wagenstellplatz /empty wagon storage area

- Klappbare Wechselbehälterunterstützung (aussen) /outside foldable swap body support
- S Vmax. 100 km/h ohne besondere betriebliche Bedingungen /Vmax. 100 km/h without special operational conditions
- SS Vmax. 120 km/h ohne besondere betriebliche Bedingungen /Vmax. 120 km/h without special operational conditions

**WECHSELCONTAINER ZUGEHÖRIGKEIT DER GRUPPE M2 /Exchange container affiliation of the group M2:**

**A. Symmetrische Abmessungen**  
*A. Symmetrical dimensions*

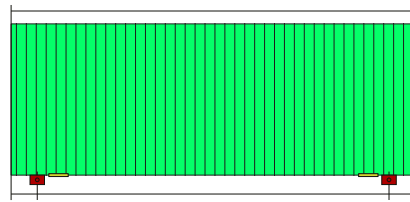

Gruppen Nr. <i>Group nr.</i>	Max. Länge (mm) <i>Max. length (mm)</i>	Max. Überhang (mm) <i>Max. overhang (mm)</i>	Befestigungsbeschlag Mindestabstand (mm) <i>Mounting bracket minimum distance (mm)</i>	Maximaler Überhang (mm) <i>Max. overhang (mm)</i>
20	6058	102.5	5853 +/- 3	102.5
21	6250	198.5	5853 +/- 3	198.5
22	7150	648.5	5853 +/- 3	648.5
23	7450	798.5	5853 +/- 3	798.5
24	7820	983.5	5853 +/- 3	983.5
26	8150	1148.5	5853 +/- 3	1148.5
30	9125	103.5	8918 +/- 4	103.5
31	9300	191.0	8918 +/- 4	191.0
40	12192	103.5	11985 +/- 5	103.5

**B. Asymmetrische Abmessungen**  
*B. Asymmetrical dimensions*

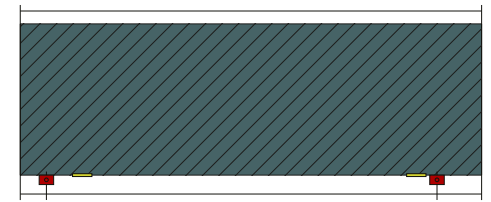

Gruppen Nr. <i>Group nr.</i>	Max. Länge (mm) <i>Max. length (mm)</i>	Max. Überhang (mm) <i>Max. overhang (mm)</i>	Befestigungsbeschlag Mindestabstand (mm) <i>Mounting bracket minimum distance (mm)</i>	Maximaler Überhang (mm) <i>Max. overhang (mm)</i>
60	8543	1190.0	5853 +/- 3	1500.0
81	9275	103.5	8918 +/- 4	253.5
82	9330	103.5	8918 +/- 4	308.5
84	10040	103.5	8918 +/- 4	1018.5
85	10200	103.5	8918 +/- 4	1178.5
86	10900	103.5	8918 +/- 4	1878.5